

**INSTALLATION MANUAL AND INSTRUCTIONS FOR USE**



**PART NUMBERS AND ACCESSORIES**

Part number	Description	
487A01	Mobile motorized height adjustable stand travel 26"[660 mm] black max 254 Lbs.(115kg)	120 V / 60 Hz
487A01002	Mobile motorized height adjustable stand travel 26"[660 mm] black max 254 Lbs.(115kg)	240 V / 50 Hz
481A101	Laptop or keyboard support tray bottom mounting	
481A102	Adapter set for screens with VESA 700x500, 700x600, 800x500 and 800x600	
481A103	Adapter set for screens with VESA 700x200, 700x400, 800x200 and 800x400	
481A104	Conferencing camera support tray bottom mounting	
481A105	Universal bracket for soundbar mounting	



## General warnings:

This product is intended for installation by a trained professional (the installer), do not attempt to install the product yourself.

A correct installation of this product is extremely important for the safe and correct use of it. The installer must follow the instructions in this manual for correct installation. Not doing so may result in injury to persons or damage to equipment. The manufacturer is not responsible for and does not control the correct installation according to this installation manual.

Mounting hardware for installation to a wall or ceiling is never included with the product for reasons of safety, because the material properties of the load bearing walls or ceilings can be different for each case. Suitable mounting hardware for a specific situation should be selected by a trained installer, when in doubt consult a building engineer.

It is the responsibility of the installer to ensure that the wall/ceiling can support at least four times the combined weight of the screen plus the mounts. The maximum load for this product is specified in this installation manual.

Hardware for the correct installation of the mount and the screen is included with the product, use the supplied hardware for its intended purpose. Do not use alternative hardware before consulting with the manufacturer of the product.

Follow the mounting instructions and warnings for installation and use of the screen supplied by the screen manufacturer, make sure the weight specifications of the screen used plus other brackets and hardware is within the weight limits specified for the use of the mount.

## Warranty terms and conditions:

1. Manufacturer guarantees that a product that manufacturer has determined to be defective as a result of a manufacturing or material defect will be repaired or replaced (to be determined by Manufacturer), without cost, on condition that a claim is made within the period of warranty, which is 3 years.
2. In the event of a claim being made under the terms of the warranty, the product needs to be returned to the manufacturer by the installer accompanied by a RMA form, which we will send on request. The freight costs from the installer to the manufacturer are covered under the terms of the warranty provided the RMA instructions are followed with regard to the forwarder.
3. The guarantee provided by manufacturer shall lapse or be void if:
  - a defect arises as the result of incorrect or inexpert assembly or installation.
  - in case of improper use or any use not in accordance with the instructions.
  - in case of normal wear and tear.
  - without the written consent of the manufacturer, customer or a third party have introduced changes to the product or have attempted to do so, the product has been used for anything other than its intended use or if products were processed or revised in some way other than was instructed.
  - A customer or a third party engaged by customer performed repairs without the written consent of the manufacturer.

## The intended use of the product:

The product is intended to be used for the mounting and height adjustment of passive or interactive flatscreen display panels. The product is intended for in-door use in classrooms, offices or meeting rooms, at temperatures ranging between 50 and 104 °F / 10 to 40 °C.

The product is intended for use by adults; children under the age of 16 should only use the product under adult supervision.

## Specifications and limitations of the product:

Maximum weight capacity:	<b>254lbs / 115kg</b>
Maximum screen size:	<b>86" diagonal</b>
Maximum slope during moving:	<b>10 degrees</b>

## The manufacturer:

**Thomas Regout Inc;** 121 Smokehill Lane  
Woodstock 30188 GA USA

**Regout Balance Systems B.V;** Industrieweg 40  
6219NR Maastricht; The Netherlands

## DISCLAIMER

The manufacturer and its affiliated corporations and subsidiaries, intend to make this manual accurate and complete. However, the manufacturer makes no claim that the information contained herein covers all details, conditions or variations, nor does it provide for every possible contingency in connection with the installation or use of this product.

The information contained in this document is subject to change without notice or obligation of any kind. The manufacturer makes no representation of warranty, expressed or implied, regarding the information contained herein. The manufacturer assumes no responsibility for accuracy, completeness or sufficiency of the information contained in this document.

All rights reserved.

## IMPORTANT SAFETY INSTRUCTIONS



### WARNING:

Failure to read, thoroughly understand, and follow all instructions can result in serious personal injury, damage to equipment, or voiding of factory warranty! It is the certified installer's responsibility to make sure all mounting systems/ accessories are properly assembled and installed using the instructions provided.

### WARNING:

Failure to provide adequate structural strength for this mounting system can result in serious personal injury or damage to equipment! It is the certified installer's responsibility to make sure the structure to which this mounting system is attached to or placed upon is flat and even and can support at least four times the combined weight of all equipment. Reinforce the structure or surface as required before installing the mounting system.

### WARNING:

Use this mounting system only for its intended use as described in these instructions. Do not use attachments or accessories not recommended by the manufacturer.

### WARNING:

Never operate this mounting system if it is damaged. Return the mounting system to your dealer, a service center or contact the manufacturer for examination and repair.

### WARNING:

Do not use this product outdoors.

### WARNING: RISK OF INJURY TO PERSONS!

Do not place video equipment such as televisions or computer monitors on cart legs. (where applicable)

### WARNING:

Exceeding the weight capacity can result in serious personal injury or damage to equipment! It is the certified installer's responsibility to make sure the combined weight of all accessories and equipment attached to the 487A01 assembly up to (and including) the display does not exceed the maximum load of 254 lbs / 115 kg. Use with heavier screens may result in instability causing tip over resulting in death or serious injury! The height adjustable feature of this trolley will not function properly if the weight exceeds the given maximum load.

### WARNING: RISK OF SERIOUS INJURY OR DEATH!

Placing a remote control or toy on the trolley or wall mount may encourage a child to climb onto the product causing the trolley to tip over onto the child. DO NOT place remote controls or toys on the product!

### WARNING: RISK OF SERIOUS INJURY OR DEATH!









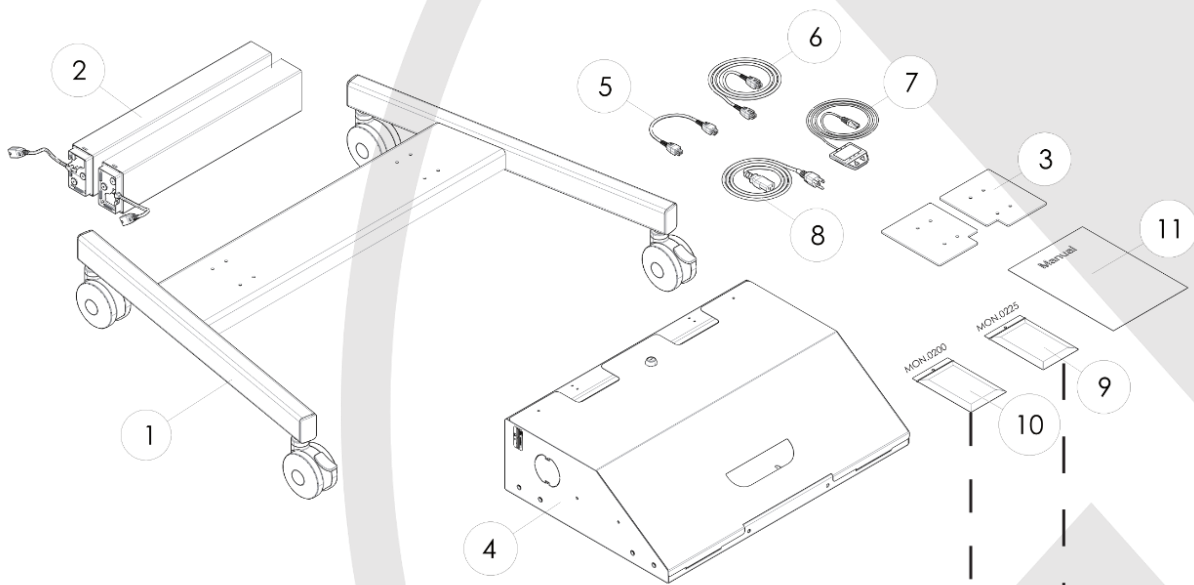
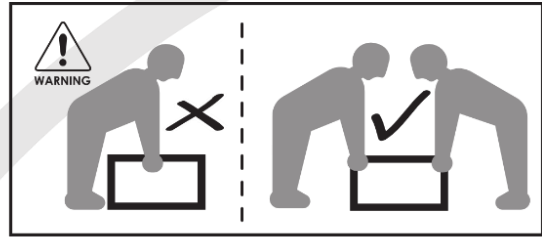

Relocating audio and/or video equipment to the trolley may result in the trolley collapsing or overturning onto a child. DO NOT relocate audio and/or video equipment to the trolley!

### NOTE:

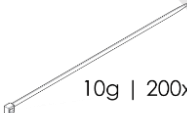
The motorized height adjustable stand or wall mount can support all kinds of screen sizes as long as the distance between floor frame and bottom screen is at least 2 inch / 50mm. The intended maximum screen size is 86" diagonal.

UNPACKING / CONTENT OF THE PACKAGING



MON.0200		MON.0225	
 10a   M6x12   4x		 9a   M6x20   16x	
 10b   M6x25   4x			
 10c   D25, d8.4x30   4x	 10g   200x3.6   2x		
 10d   M8x14   4x	 10h   25x45x1   1x		
 10e   M8x25   4x	 10i   98x21   1x		
 10f   M8x45   4x			

ASSEMBLY

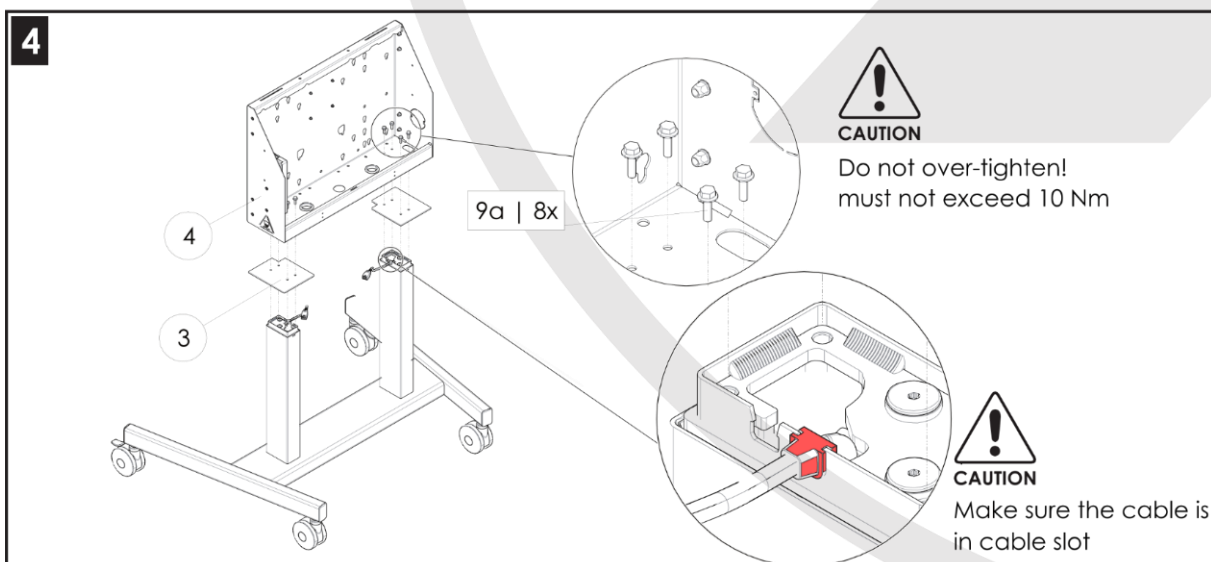
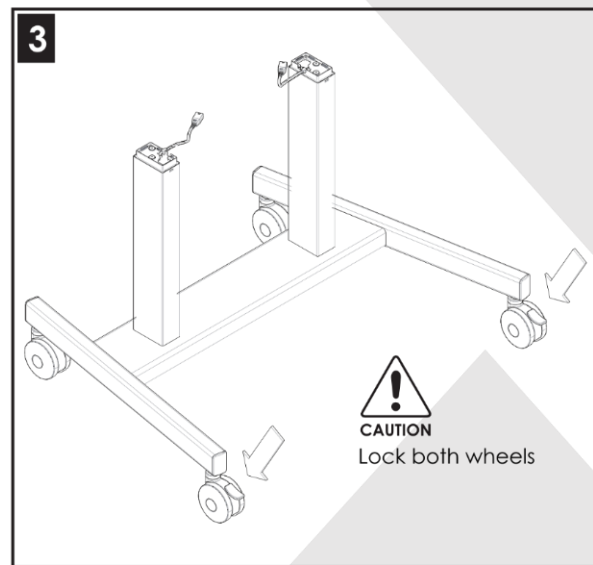
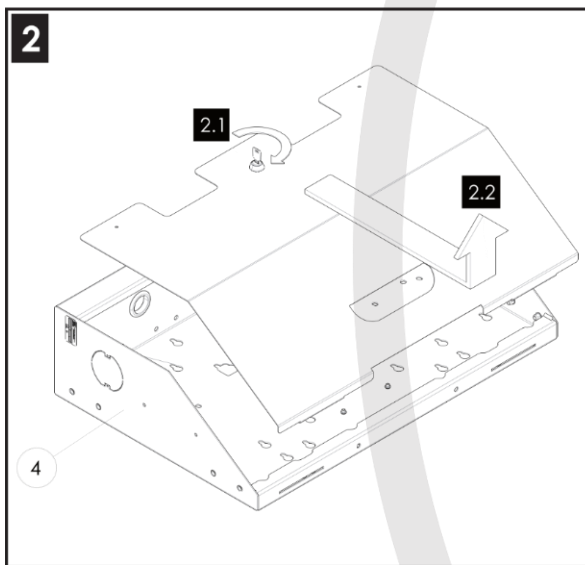
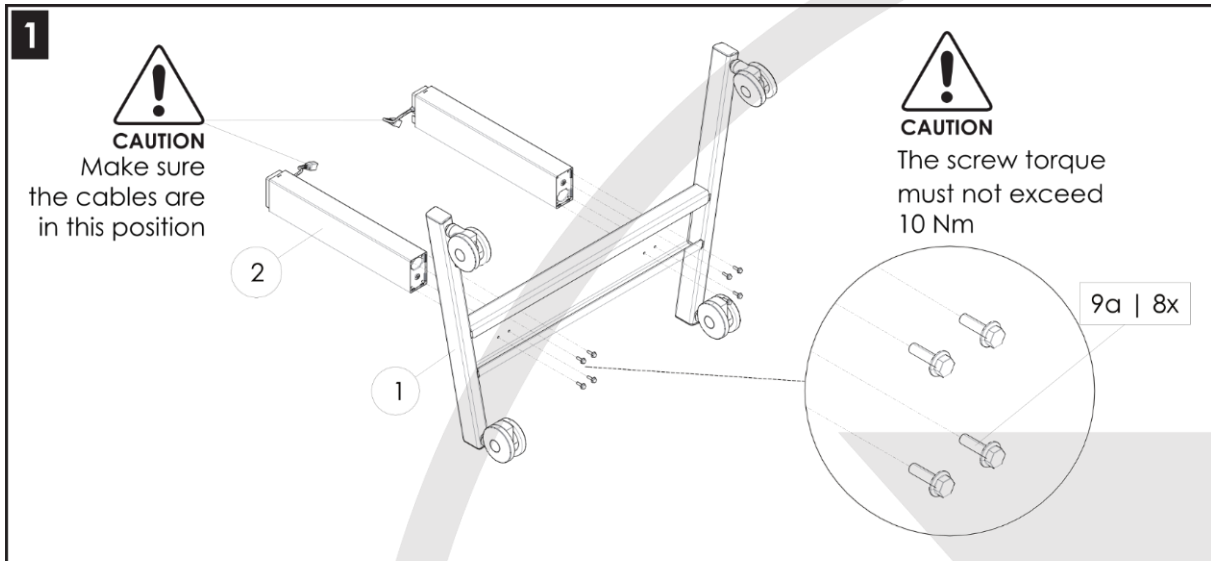

**ASSEMBLY / MOUNTING THE SCREEN**

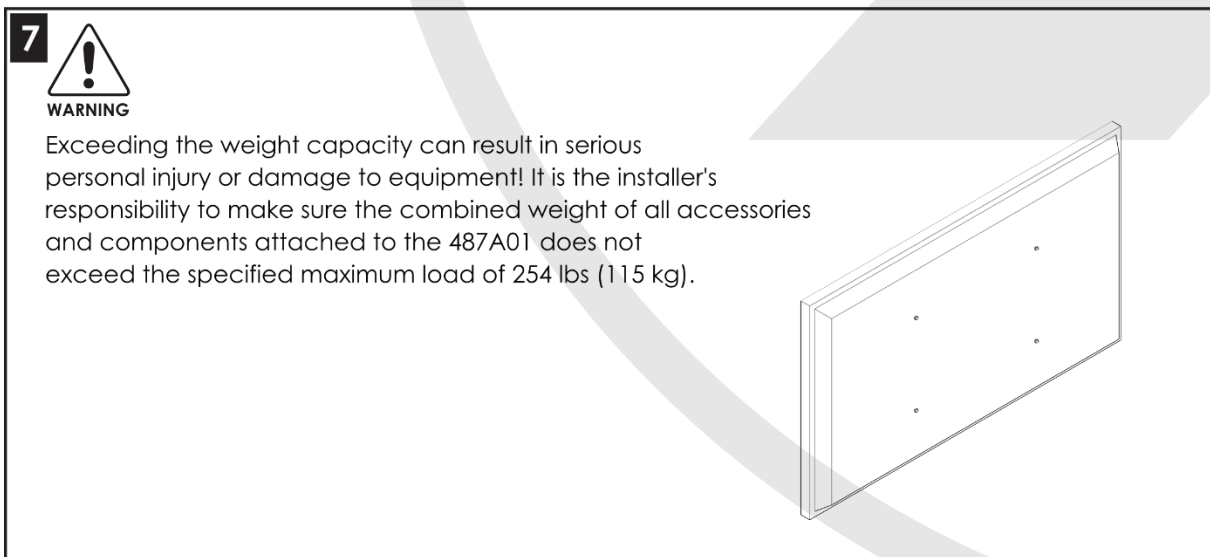
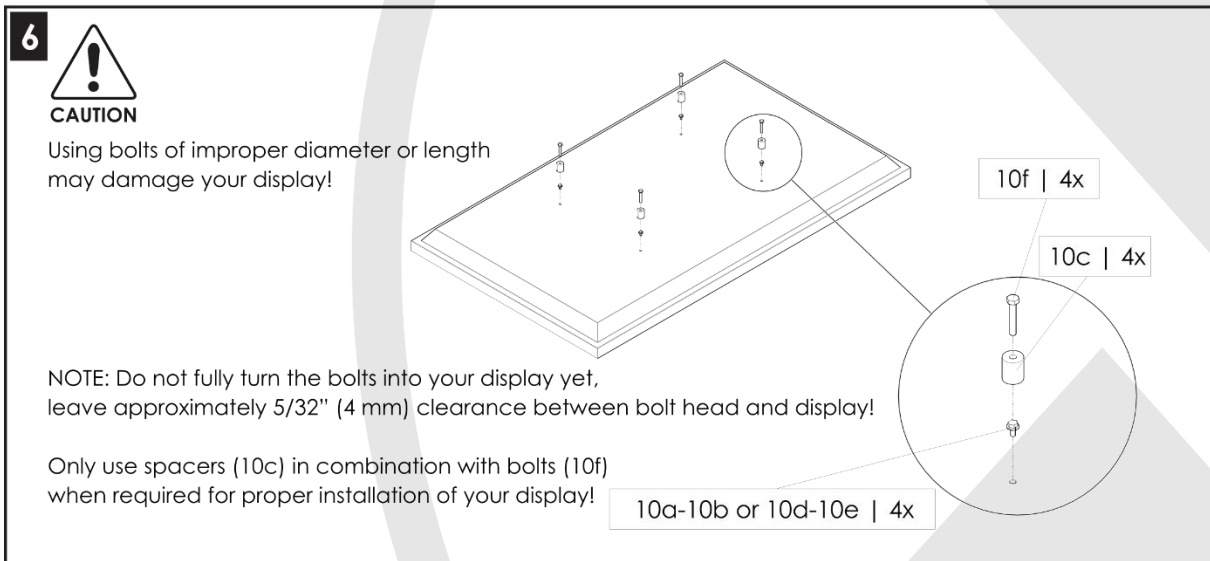
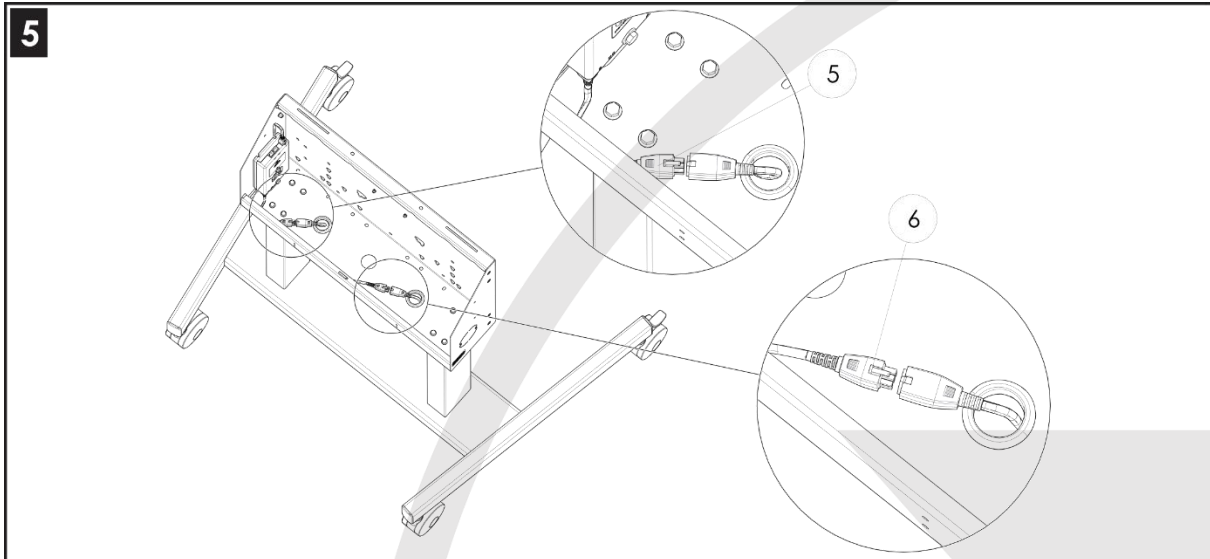

**MOUNTING THE SCREEN**

**8**

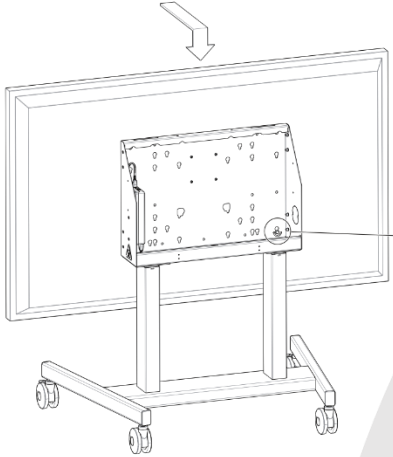

**WARNING**  
Always lift with two people and use proper lifting techniques when installing or mounting the display!

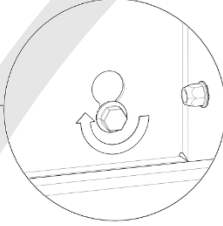

**NOTE:** After mounting the display, tighten the four bolts!

**9**

**WARNING**  
Overriding the minimum distance can cause serious injury or damage to the equipment! It is the installer's responsibility to ensure the minimum distance in all cases, including all accessories and components attached to the 487A01, does not exceed the specified minimum distance of 1,97 inch (50mm).

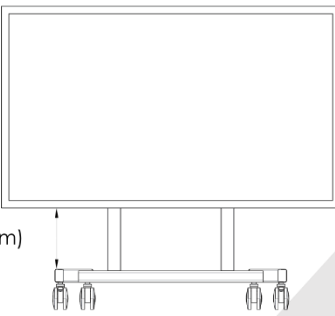

min. 2" (50 mm)

**10**

**WARNING**  
Hazardous moving parts, keep fingers and other body parts away  
It is the installer's responsibility to place the marking [10i] in a prominent position, close to the remote (7), readily visible and accessible from the point where the risk of injury is greatest.

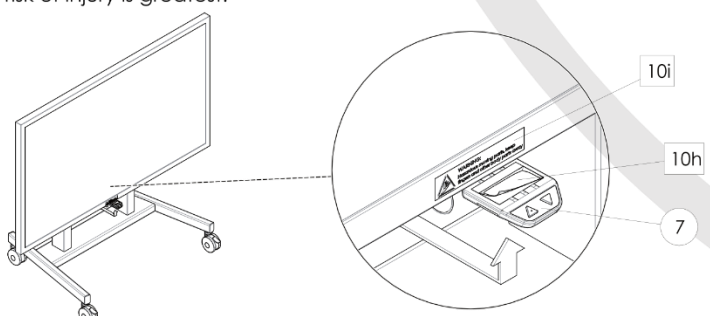

10i  
10h  
7

**MOUNTING THE SCREEN**

**11**



**WARNING**

Inadequate wiring and installation of electrical equipment can cause serious injury or damage to the equipment!  
It is the installer's responsibility to ensure the wiring and installation of all components added to the 487A01 is according local regulations.

10g | 2x

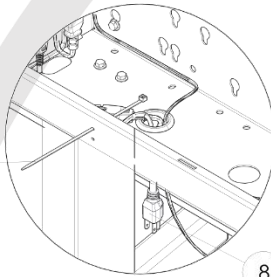

8

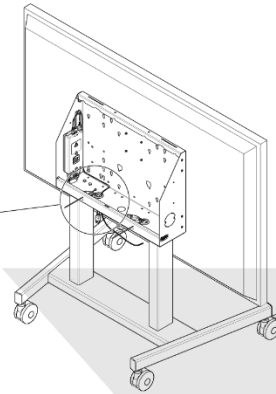

**12**

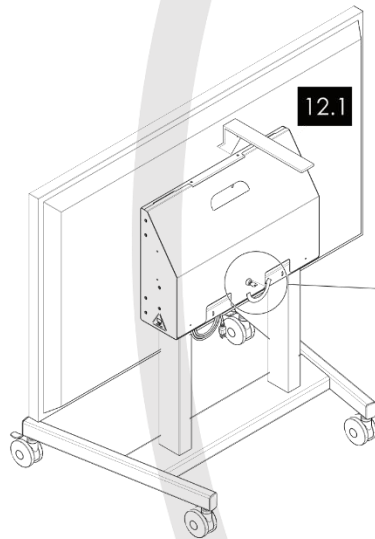

**12.1**

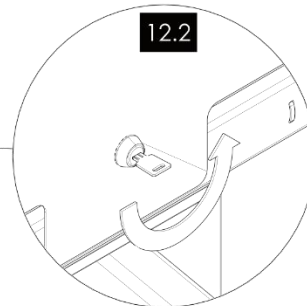

**12.2**



**INSTRUCTIONS FOR USE**

**1**



**WARNING**

Risk of serious injury or death!

1. Do not place remote controls (of 3rd party) or toys on the mobile lift system!
2. Do not relocate audio and/or video equipment to the mobile lift system!
3. Do not allow children under 16 to move the mobile lift system!
4. Always lower the display before transport!
5. Do not pull, but push! Move slowly, always push toward the middle, never apply force at top!



**WARNING**

Hazardous moving parts keep fingers and other body parts away

1. Make sure the area around the lift system is clear before use of the remote up or down button!

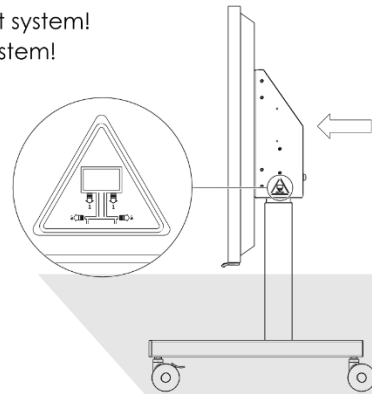

**2**



**WARNING**

Risk of serious injury or death!

1. Do not pull down slope!
2. Always stay above mobile lift system when moving down slope!
3. Make sure the display is in the lowest position!
4. Do not raise the display with the lift system on a slope!

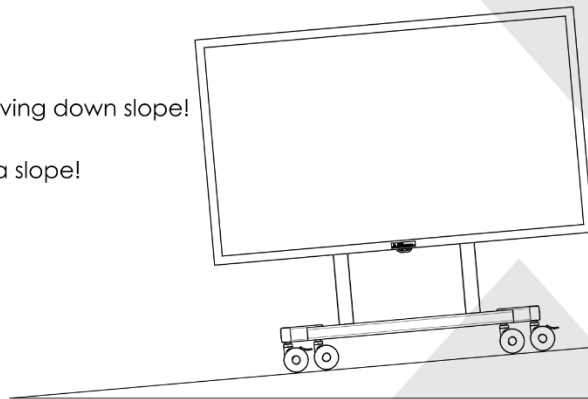

**3**

1. Place the e-Box Mobile on a horizontal and flat surface!
2. Make sure that the wheels are locked before use!
3. Insert the mains plug into the outlet.  
The equipment shall be so installed that socket-outlet shall be near the equipment and shall be easily accessible.
4. Push the up button to lift the display up.
5. Push the down button to lower the display.

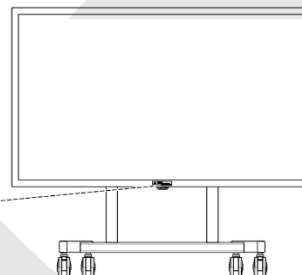

RESET CONTROL BOX – MOTOR SYNCHRONISATION

**1**

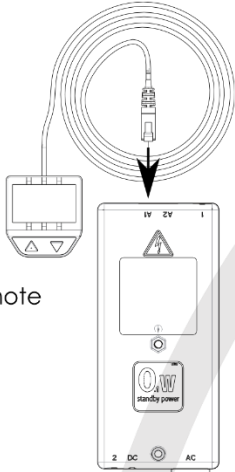

Make sure the remote is connected to the controlbox

**2**

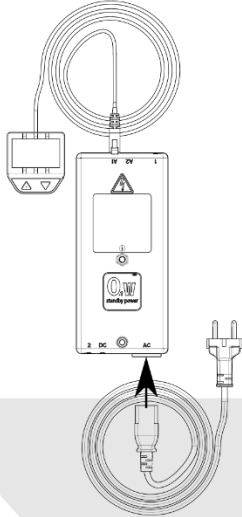

Make sure the power lead is connected to the controlbox

**3**

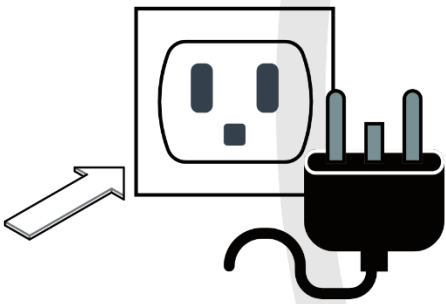

Connect the power lead to the wall socket

**4**

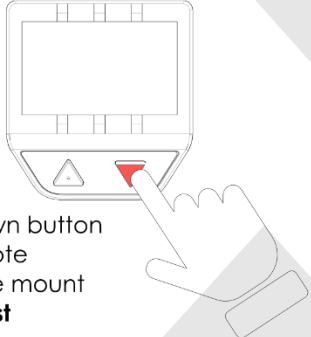

Use the down button on the remote to move the mount to the **lowest** position

**5**

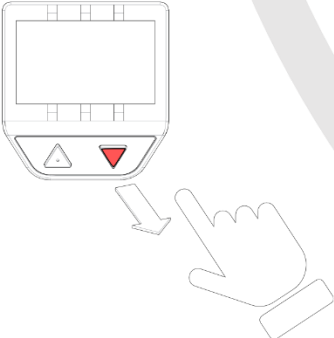

Release the down button

**6**

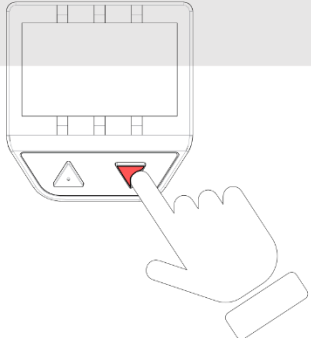

Push the down button for 30 sec



**RJ45 CONNECTION DIAGRAM**

**RJ45 - 8 PIN CONNECTION DIAGRAM**

**WARNING:**

The height adjustable mount can only be operated remotely when visual supervision of the moving products is possible. Operating the product without visual supervision may result in serious injury or death.

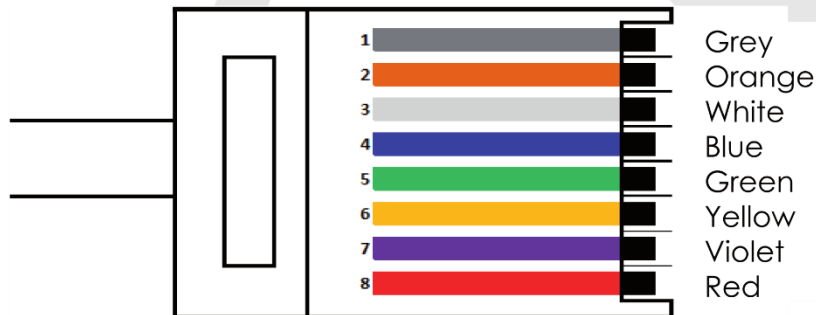

Cable wire color	Function	RJ45 8 Pin plug no.
Blue + Green	Reference 1 Up	RJ45 Pin 4 + 5
Blue + Red	Reference 1 Down	RJ45 Pin 4 + 8
White + Green	Reference 2 Up	RJ45 Pin 3 + 5
White + Red	Reference 2 Down	RJ45 Pin 3 + 8
Orange + Green	Reference 3 Up	RJ45 Pin 2 + 5
Orange + Red	Reference 3 Down	RJ45 Pin 2 + 8



L = 1700 mm +/- 70 mm

